



STEPS TO CONSTRUCTING A MOISTURE-RESISTANT FOUNDATION

Details are critical when constructing a sound building foundation that will withstand water and control dampness. Foundation repairs are often difficult and expensive, so it's important to build the foundation correctly the first time. The Build A Better Home program from APA – The Engineered Wood Association is designed to provide builders and homeowners with the construction guidelines they need to protect their homes against damaging moisture infiltration. Key elements in the building envelope are the roof, walls, and foundations. This publication discusses common sources of moisture and addresses design details for foundations.

SOURCES OF MOISTURE IN NEW CONSTRUCTION

There are several common causes of water intrusion into floors, crawl spaces and basements.

1. Rainwater, either flowing from the ground or draining from the roof, can flow into the side of the foundation and then into the crawl space or basement.
2. Rainwater can enter the ground and flow through the soil into the area under the house.
3. Natural springs sometimes emerge under homes. They may appear only seasonally.
4. Groundwater levels can rise and fall seasonally. Sometimes the groundwater table can actually rise all the way to the surface.

FIGURE 1
WATER TABLE SLOPE

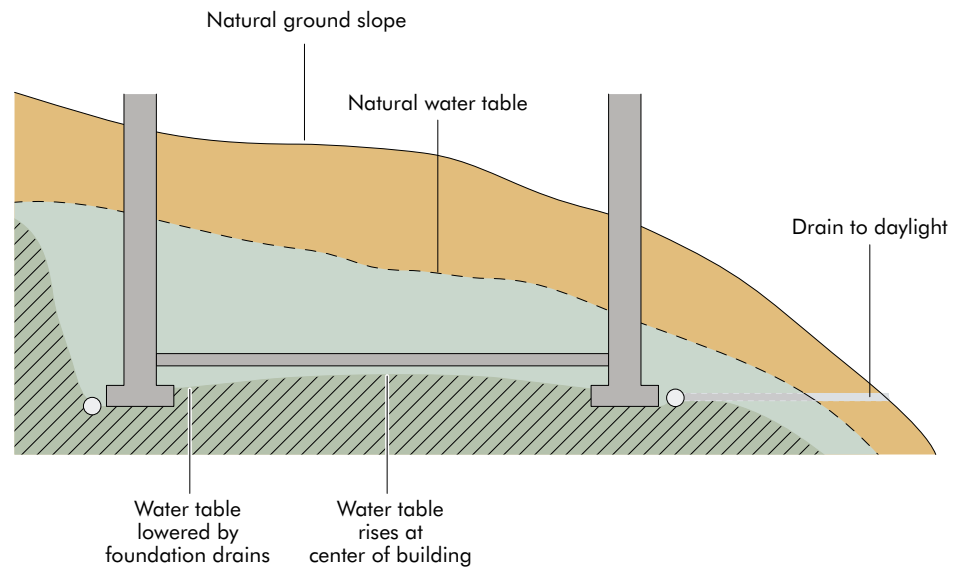

5. Groundwater below the level of the floor or foundation can wick upward through the soil by capillary action and cause dampness in basements, crawl spaces and slab floors. In very fine soils or clays, this capillary rise can be as much as eight feet above the groundwater table.

6. New concrete will usually be damp to the touch for several weeks or even months. This is because new concrete contains excess water and the dampness occurs as the water evaporates. This type of dampness is not a long-term problem.

7. During construction, landscaping, remodeling or just over time, existing footing drain (perimeter drain) systems can become clogged with dirt or tree roots, crushed, broken, or severed. Subsequent water backup may cause dampness or even flooding.

GENERAL CONSIDERATIONS AND PREVENTIVE MEASURES

The following construction practices will minimize water problems in many foundation installations. While common in commercial construction, many of these suggested practices are often omitted in residential construction. In addition to following these preventive steps, it's a good idea to consult an engineer to insure the foundation is designed and built correctly. In some cases, a geotechnical survey is also recommended.

Identify and Design for Expansive Soils

These soils are clays that absorb moisture within each fine particle. In the process, they expand with enough force to crack or collapse all but the strongest walls and floors. Cracks in a basement wall provide a more direct path for water intrusion in addition to increasing the potential for structural damage.

Typically, expansive soils are removed and replaced by a backfill material consisting of soils or gravels that do not expand when wet. When building on expansive soils, it is doubly important that rain or groundwater does not get under the footing or floor slab.

Install a Footing Drain

A footing drain (Figures 2, 3, 5, and 6) is one of the most essential features and is common to all types of foundations. It should be installed around the perimeter of the foundation and discharged to a suitable location downhill from the home, into a drywell or into a storm sewer system.

(Where soil, adjacent structures or ground elevations prevent gravity drainage, a sump must be installed and the water pumped to a dry well, or discharged downhill from the house. If the water is pumped to a storm sewer, a licensed plumber may be required to install the connection to the sewer.)

Install a footing drain as follows:

1. Place a geotextile (filter) fabric on the bottom of the excavation.
2. Cover with four inches of one-size, clean, 3/4-inch crushed stone or gravel.
3. Place four-inch minimum diameter perforated drainpipe over the gravel if the soil is clay. Use a six-inch perforated pipe if the soil is sandy and there is a lot of water to redirect. Orient the perforations down. The drainpipe may be laid level along the footing.
4. At the point where the footing drain leaves the perimeter of the house, connect the perforated footing drain to an unperforated drainpipe of the same diameter and run to a downhill area, away from the house, to a drywell, storm sewer or to a suitable location for an above-ground discharge.
5. Cover the perforated drainpipe with about six inches of clean gravel and cover the gravel with the geotextile fabric.

PREVENTIVE MEASURES FOR SPECIFIC FOUNDATION TYPES

Most homes are built on one of three types of foundations: slab-on-grade, crawl space, or full basement. Pressure-preservative-treated wood, masonry, post-and-pier and pilings are occasionally used. Only concrete and masonry (concrete block) foundations are addressed in this publication, although the principles of good practice are common to others.

Slab-on-Grade Foundation

Slab-on-grade foundations are simple to build because the floor and footing can be poured as one unit. The floor is typically at, or only slightly above, ground level. Walls of any height can be formed on top of the slab-on-grade foundation system.

If fine soils or clays are present, and the water table may rise to within ten feet of the surface, the ground should be specially prepared to receive a slab floor (Figure 2).

1. Install a drainage and capillary break of three inches of 3/4-inch single-size coarse aggregate over the ground. This gravel should be compacted.
2. Over the gravel, place a layer of geotextile fabric.
3. Place 1/2 inch of compactable sand over the geotextile fabric and compact well.
4. Place a layer of polyethylene (or reinforced polyethylene for greater puncture resistance) over the 1/2 inch of compacted sand.
5. Place four inches of compacted sand over polyethylene. The sand should be sufficiently compacted to prevent a fully loaded premix concrete truck from indenting the fill more than 1/2 inch.

6. Pour the slab over the sand.

Note that excess water in concrete evaporates and leaves microscopic holes through which water can move. To minimize concrete porosity use a low water-cement ratio concrete mix with a high cement content and a superplasticizer additive.

Slope the ground surface away from the house and foundation. Make sure that all water from downspouts is discharged away from the house into a drywell, storm sewer or suitable ground-surface location downhill from the house.

Crawl Space Foundations

This type of foundation is typically used to permit the construction of a wood-framed floor system above the ground. The crawl space under the floor provides access to wiring, plumbing and heating ducts from under the floor. The foundation is composed of a separate perimeter footing plus concrete or masonry walls that may be only a few inches high to several feet high. The unfinished dirt floor of this type of foundation system may be at or below ground level (Figure 3).

The footing drain and gutter/downspout discharge systems should be installed the same way as for the slab floor described above. Through-wall connections for water, sewer and electrical should be minimized and thoroughly sealed (Figure 4). Again, make sure that the ground slopes away from the footings.

Crawl space ventilation should be provided to facilitate natural air circulation. There should be at least four ventilation openings with at least one on each wall around the perimeter. Ventilation openings should be as high on the

FIGURE 2
SLAB-ON-GRADE FOUNDATION

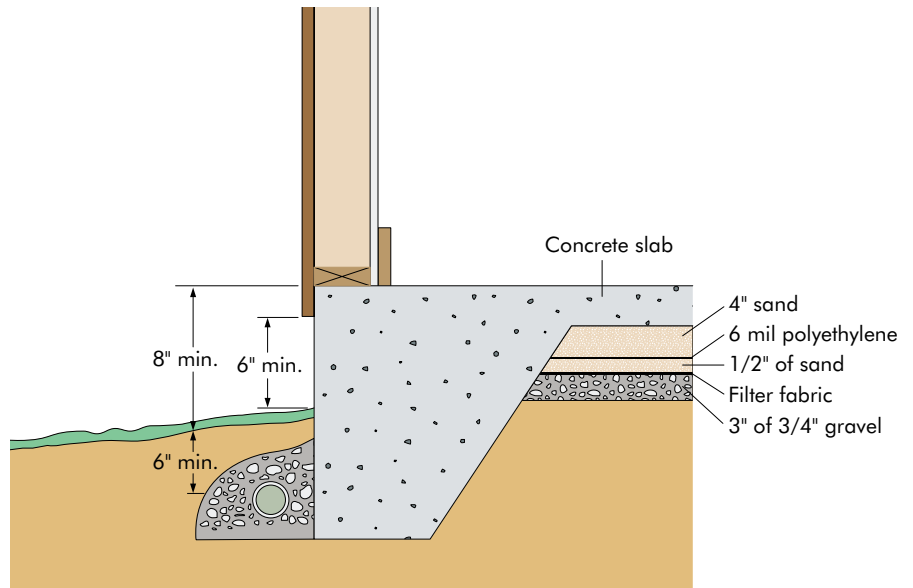
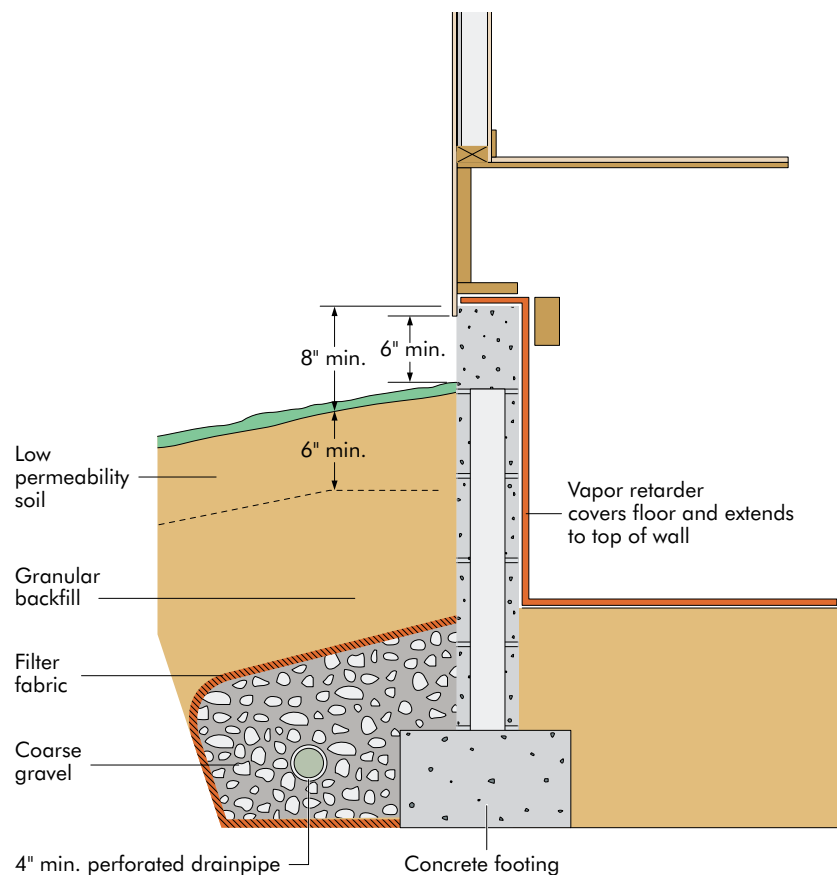

FIGURE 3
CONCRETE MASONRY CRAWL SPACE FOUNDATION



foundation walls as possible and the total area should be evenly distributed among the walls.

Use this formula to calculate the required total size of the openings:

$$a = \left(\frac{A}{150} \right)$$

Where:

a = net free area of all vents (sq. ft)

A = area of crawl space (sq. ft)

There should be a six-mil minimum-thickness polyethylene ground cover over bare ground under the house to prevent ground moisture from escaping into the crawl space. Overlap the edges at least six inches and follow manufacturer's recommendations to seal all edges with tape or adhesive. Tape polyethylene to walls and around all objects protruding through the polyethylene. When the polyethylene is installed as recommended, the ventilation area may be reduced to 10 percent of the area calculated by the above equation.

Full Basement Foundation

This is actually a variation of the crawl space foundation but with full-height walls and a concrete floor. The basement walls may be below grade (ground level) on all sides. On hillsides, one or more sides of the basement may be above or partially above grade.

The same steps that were taken for the slab foundation floors also apply to basement floors. Concrete vibrators should be used to prevent the formation of voids and cold joints in the walls. A liberal use of steel reinforcing bars in the basement walls will help minimize cracking and increase structural

FIGURE 4

THROUGH-WALL SEALING

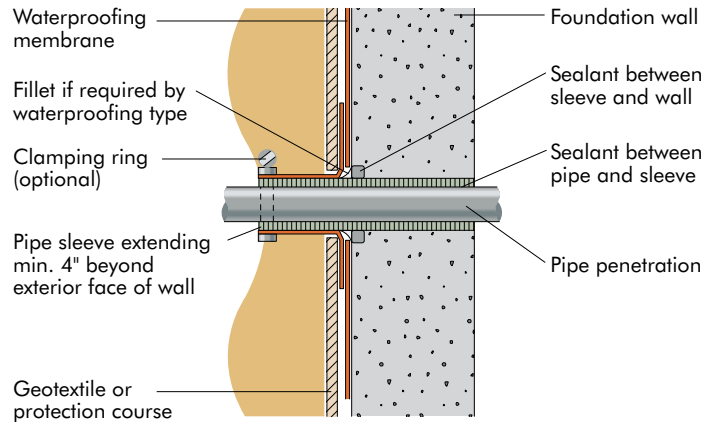

strength. Use low water/cement ratio concrete with a high cement content. Superplasticizers will facilitate the workability of this concrete mix.

The following steps will help assure a water-free interior:

1. Minimize through-wall penetrations for water, sewer and electrical connections and seal all such penetrations to prevent water leakage. Seal around all joints and penetrations for pipes and conduits (Figure 4).
2. Coat the walls with a suitable waterproofing material such as asphaltic mastic. Follow manufacturer's directions. This will be the backup system to help seal any existing or future minor cracks that may admit water.
3. When the natural water level is high up on the wall, the sealer should be covered with a waterproof membrane capable of withstanding the water pressure without leaking, even if a footing drain has been installed. When such a system is used, the components should

all come from the same manufacturer to better assure compatibility of components.

4. Attach a drainage mat to the wall, over the waterproof membrane or sealer, to provide a free pathway for water to flow to the footing drain. Gravel can also be used to create a drainage pathway to the footing drain but care should be taken to not tear the waterproof membrane when placing the gravel (Figure 6).

5. Place a geotextile (filter) fabric on the bottom of the excavation and cover with four inches of one-size clean 3/4-inch crushed stone or gravel.

6. Place four-inch-minimum-diameter perforated drainpipe over the gravel if the soil is clay. Use a six-inch perforated pipe if the soil is sandy and there is a lot of water to redirect. Orient the perforations down. The drainpipe may be laid level along the footing.

FIGURE 5

FULL-BASEMENT FOUNDATION WALL WITH MAT DRAINAGE

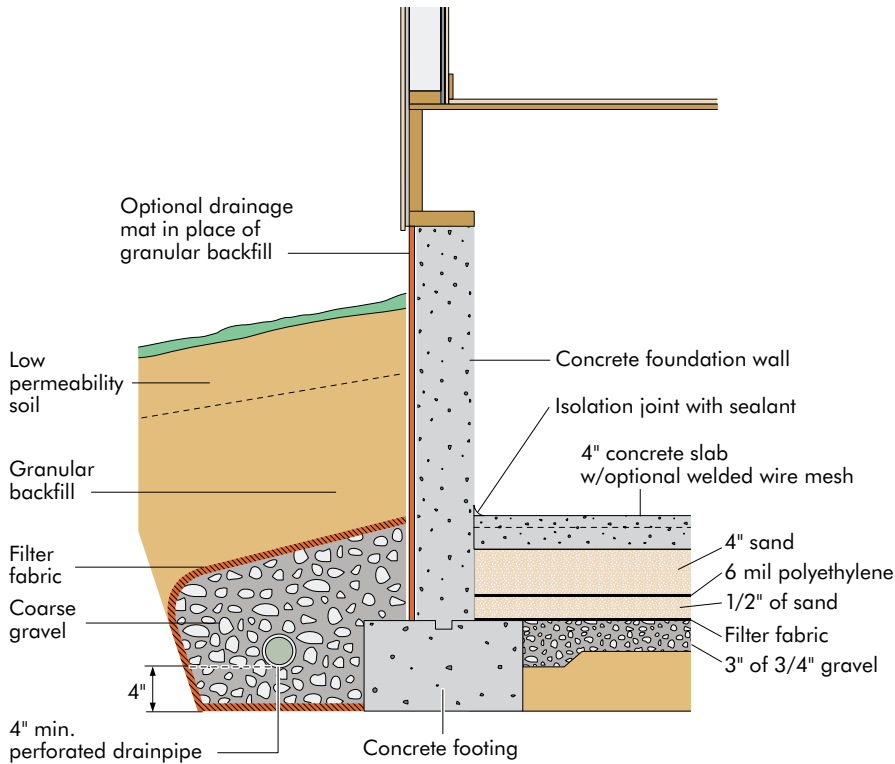
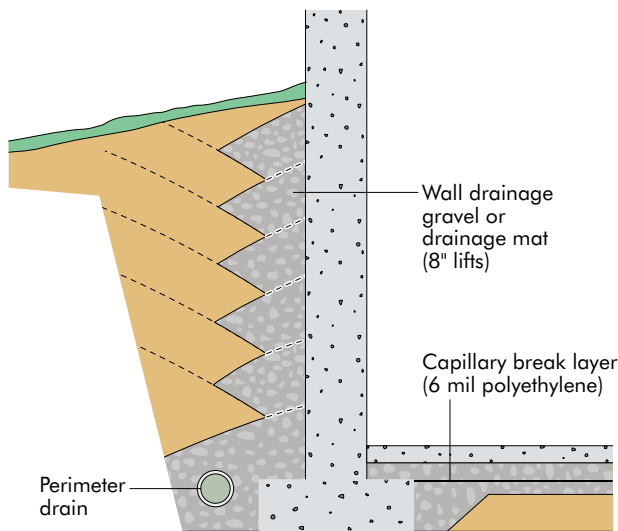

FIGURE 6

FULL-BASEMENT FOUNDATION WALL WITH GRANULAR DRAINAGE



7. At the point where the footing drain leaves the perimeter of the house, connect the perforated footing drain to an unperforated drainpipe of the same diameter and run to a downhill area, away from the house, to a drywell, storm sewer or suitable location for an above-ground discharge.

8. Cover the perforated drainpipe with about six inches of clean 3/4-inch gravel and cover the gravel with the geotextile (filter) fabric.

9. Backfill the excavation. Compact the soil carefully in layers as backfill is added. Avoid over-compaction because that may damage the wall structurally.

BASIC CONSIDERATIONS IN FOUNDATION DESIGN

Attention to details in foundation construction will prevent damaging moisture build-up and infiltration and make it easier to keep the floor and crawl space areas dry. Here are a few important principles:

1. Water runs downhill, even when underground.
2. Dammed-up water will cause pressure against a wall that can increase the risk of leaks.
3. Natural, unenhanced concrete, mortar and block are porous.
4. Even well-constructed concrete walls will crack – at least on a microscopic level. It is therefore advisable to take steps that will prevent water from going through these cracks.
5. It is always easier and cheaper to prevent water problems than it is to fix them later.

ADDITIONAL INFORMATION

About APA – The Engineered Wood Association

APA – The Engineered Wood Association is a nonprofit trade association whose member mills produce approximately 70 percent of the structural wood panel products manufactured in North America.

The Association's trademark appears only on products manufactured by member mills and is the manufacturer's assurance that the product conforms to the standard shown on the trademark. That standard may be an APA performance standard, the Voluntary Product Standard PS 1-95 for Construction and Industrial Plywood, or Voluntary Product Standard PS 2-92, *Performance Standards for Wood-Based Structural-Use*

Panels. Panel quality of all APA trademarked products is subject to verification through an APA audit.

APA's services go far beyond quality testing and inspection. Research and promotion programs play important roles in developing and improving panel and engineered wood systems, and in helping users and specifiers better understand and apply products.

For additional information on wood construction systems, contact

APA – The Engineered Wood Association,
P.O. Box 11700, Tacoma, Washington
98411-0700.

More Information Online

Visit APA's web site at apawood.org for more information on engineered wood products, wood design and construction, and technical issues and answers.

Online publication ordering is also available through the web site.

We have field representatives in most major U.S. cities and in Canada who can help answer questions involving APA trademarked products. For additional assistance in specifying APA engineered wood products, contact us:

APA – THE ENGINEERED WOOD ASSOCIATION HEADQUARTERS

7011 So. 19th St. ■ P.O. Box 11700
Tacoma, Washington 98411-0700
(253) 565-6600 ■ Fax: (253) 565-7265



www.apawood.org

PRODUCT SUPPORT HELP DESK

(253) 620-7400
E-mail Address: help@apawood.org

(Offices: Bournemouth, United Kingdom;
Hamburg, Germany; Mexico City, Mexico;
Tokyo, Japan.)

The product use recommendations in this publication are based on APA – The Engineered Wood Association's continuing programs of laboratory testing, product research, and comprehensive field experience. However, because the Association has no control over quality of workmanship or the conditions under which engineered wood products are used, it cannot accept responsibility for product performance or designs as actually constructed. Because engineered wood product performance requirements vary geographically, consult your local architect, engineer or design professional to assure compliance with code, construction, and performance requirements.

Form No. A520
Issued January 2001/0050

