

ROOF FLASHING GUIDELINES

GUIDELINES

THE MAIN OBJECTIVE OF A ROOF IS TO PROTECT THE HOUSE FROM THE ELEMENTS, ESPECIALLY RAINFALL. WATER RESULTING FROM RAINFALL MUST BE SHED AWAY FROM WALLS, CHIMNEYS, OR OTHER STRUCTURES THAT CAN BE DAMAGED BY EXCESSIVE WATER COLLECTION.

A sloped roof that meets a vertical wall (like the wall of a dormer window, or where a garage attaches to the two-story section of the house) requires special attention for water management. In ideal conditions, rain water that hits the siding will continue to flow down to the roof and then to the rain gutter. But no siding system is perfect, and inevitably some water gets behind the primary finish siding system. While the secondary drainage plane will keep water out of the wall, when it gets to the roof it must be given a way to get out of the wall and back onto the roof. If no water management strategies have been applied at the roof-to-wall transition, water can enter the building at this area, which can cause serious damage. Wet building materials can lead to mold growth, known to cause respiratory problems, and can lead to wood rot, which creates structural concerns.

There are two components for a good water management strategy at the critical roof-to-wall transition area. The first is to apply step flashing at the area where the roof connects to the wall, and to make sure that the secondary drainage plane behind the siding is integrated into the step flashing, so that any water that gets past the siding is diverted back out from behind the siding onto the roof. The second is where the roof ends at the gutter. To prevent water that is traveling down the step flashing from entering the wall system, a “kick-out” piece of flashing is needed to divert water away from the wall and into the gutter. This piece of flashing, which hangs over the edge of the roof, helps to divert water away from the adjacent wall or around any obstacles that the roof may butt into.

The five illustrated steps on page 6 show the preferred method to ensure that these flashing techniques have been done properly on a home with any sort of lap siding (wood, engineered wood products, cement board, etc). Following these steps will minimize the potential for water intrusion and contribute to a quality home. Planning for frequent inspections during construction to verify the proper sequence is being followed is also important to ensure proper implementation.



The intersection between the roof and the wall of this dormer should have a good water management strategy.

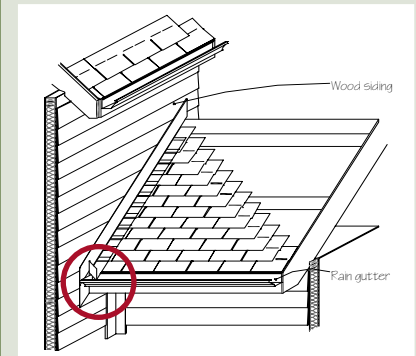

Kick-out flashing (seen in the red circle) diverts water away from the wall and into the gutter.

roof flashing guidelines

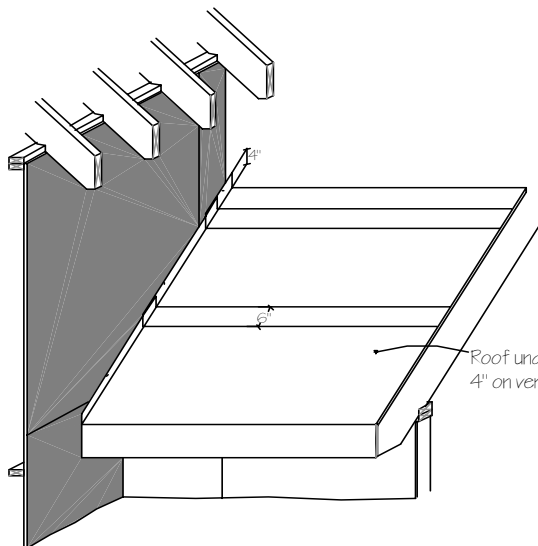

Step 1

Roofing underlayment is installed in shingle fashion with a 6-inch overlap and a 4-inch lap up the vertical wall.

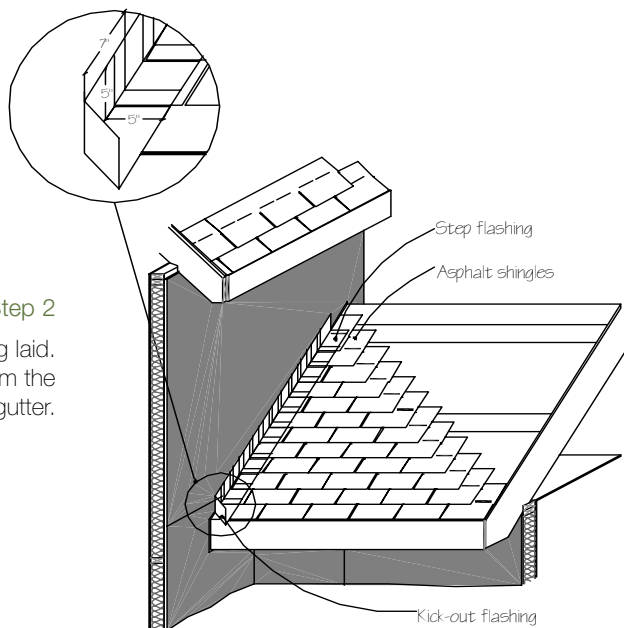

Step 2

The step flashing is installed as the roofing shingles are being laid. Kick-out flashing is installed so that water is diverted away from the adjacent wall and into the gutter.

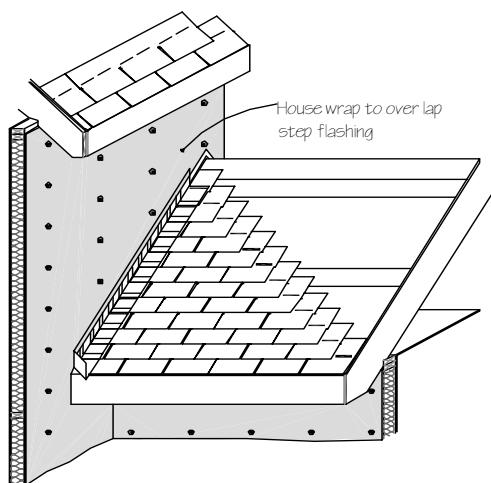

Step 3

The drainage material is installed on the vertical wall over the step flashing to ensure water drains down and away from the wall and onto the roof.

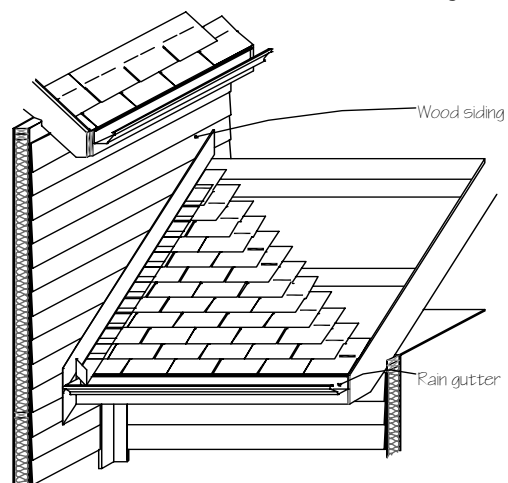

Step 4

Leave a 1 1/2-inch reveal (or gap) between the roof shingle to the siding materials. This is needed to prevent water on the roof from being wicked up into the siding material.

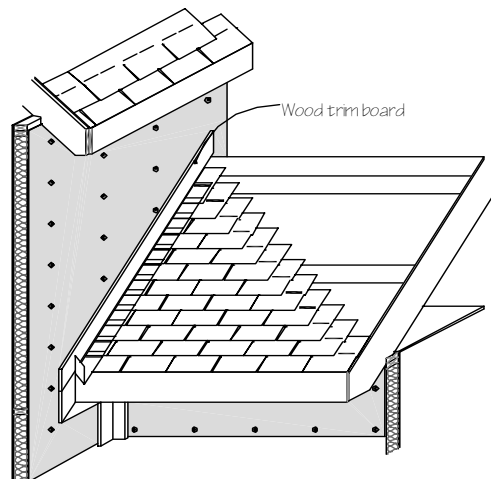

Step 5

Finally, a rain gutter is installed at the edge of the roof to complete the roofing drainage system.